



United Air Specialists, Inc.

a CLARCOR company

SFC SERIES



DOWNWARD FLOW CARTRIDGE DUST COLLECTOR

Clean air. It's what we do.®

SFC SERIES

HIGH PERFORMANCE, ENERGY EFFICIENT DUST COLLECTOR

The SFC is a proven, high-quality downward flow cartridge dust collection system. With its patented pulse cleaning technology, greater air capacity and quick and easy maintenance, there's no better air filtration method for your manufacturing facility.

Our SFC unit removes harmful pollutants resulting from common manufacturing processes — such as grinding, welding, buffing and sanding. The result: a safer, cleaner environment for your employees. By using our SFC unit, you're virtually eliminating air quality concerns in the workplace. Plus, you're ensuring increased employee productivity, fewer absences and illnesses, more efficient cleaning, and significant operational savings.



SFC 2-2

A WIDE RANGE OF APPLICATIONS

The high-performance SFC unit is ideal for all your dust and fume collection needs. Filtering out the polluted air that commonly occurs within a manufacturing environment, SFC's many industrial applications include grinding, welding, buffing, sanding, smelting, bulk powder handling, and more. Plus, our design allows for field expandability — so you can add modules and increase the capacity of your system at any time.



PATENTED PULSE CLEANING TECHNOLOGY

At the heart of the SFC system is the industry's most advanced pulse cleaning system technology. In designing the SFC unit, UAS engineers used Computational Fluid Dynamics computer modeling to develop the most effective system that "pulses off" dust from the filter — greatly improving the cartridge cleaning power. Utilizing an optimized nozzle and venturi, air is pulsed at a precisely calculated distance through an unobstructed airway. The result: Increased pulse cleaning energy, lower pressure drop and longer cartridge life. Plus, our patented pulse system cleans the full length of the cartridge. These unique, proprietary features assure years of dependable, efficient and cost effective performance.

EXTENDED CARTRIDGE LIFE WITH MORE POWER & LESS ENERGY

Unlike competitors, the SFC system uses external filter tracks to support the filters instead of "yokes" that interfere with cleaning. This allows for unobstructed airflow and increased cleaning power with less energy. By designing the SFC with optimized cabinets that broaden the space between cartridges and sidewalls, we ensured lower velocities and reduced cartridge abrasion. The result: dramatically increased cartridge life.

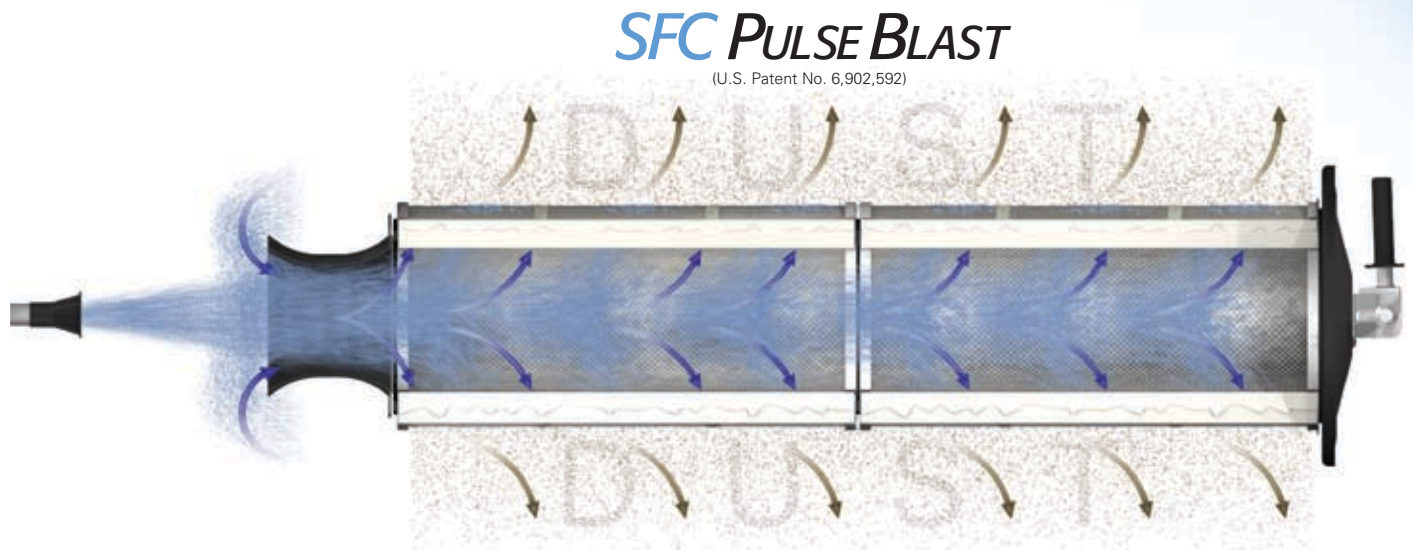

PULSE BLAST BENEFITS

FEWER PULSES are needed to clean the cartridge filters, so less compressed air is used. This is a substantial cost savings for the customer over the life of the unit.

FILTER LIFE IS INCREASED because fewer pulse cycles mean less stress on the filter media. This equates to less frequent filter changes and significant reduction in operating costs.

UNOBSTRUCTED AIRFLOW means there is more cleaning energy delivered to the filters to clean the entire length of the cartridge filter.

OPTIMIZED CLEANING provides maximum filter efficiency with the lowest possible outlet emissions.

At any point along the cartridge filter, the SFC unit provides 25% or more pulse cleaning power than the competition.

ADVANCED NANOFIBER CARTRIDGE FILTERS

All SFC Series dust collectors come with the industry's best performing, most efficient standard cartridge filter. Independently certified at MERV 15*, UAS' Advanced Nanofiber cartridge filters last 50% longer than commodity filters, and are nearly 50% more efficient on sub-micron dust particles than MERV 13 filters.

Advanced Nanofiber Filtration technology is proven to achieve higher efficiency, cleaner air, lower pressure drop, longer filter life and greater energy savings than any other standard cartridge filter media. And, when used with the SFC Series dust collector, the advantages quickly add up to unsurpassed bottom-line savings—the most efficient and best value dust collector available for industrial air cleaning processes today.

SURFACE LOADING IS KEY

UAS' Advanced nanofiber filters feature a special surface treatment of synthetic fibers so extremely fine, they are measured in fractions of a micron (nanometers). This ultra-thin layer traps dust and fume particulate on the surface of the filter before it can embed deeper in the media—leading to better cleaning efficiency with fewer pulses and significantly less compressed air use.

Our Advanced Nanofiber filters (MERV 15) are more than 85% efficient in capturing sub-micron particles from a contaminated air stream. In contrast, conventional cartridge filters, or 80/20 cellulose filters (MERV 8-10), are not capable of capturing such small particles and often require the additional use of a costly HEPA filter to ensure a safe breathing environment. This adds to overall filter cost and system upkeep.

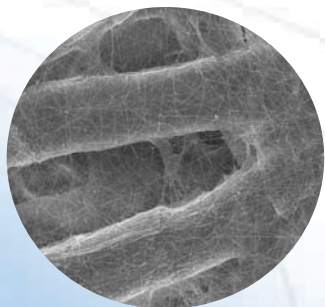

Advanced Nanofiber at 600x

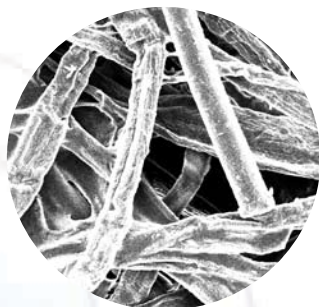

80/20 Cellulose at 600x



INVEST IN THE BEST

A cartridge dust collector is an important investment that impacts the performance of plant equipment and the health of your employees. To yield the best return and provide the safest work environment possible, it's important to choose a dust collector that utilizes an optimized pulse cleaning system to reap the full benefits of a nanofiber filter.

The result is:

LESS ENERGY USE

The SFC's patented pulse cleaning system actually uses less compressed air—a costly but necessary utility expense. This is achieved through the combination of increased power behind each pulse blast and the superior surface-loading ability of nanofiber filters. Each cleaning cycle is much more effective in removing dust from cartridge filters than other downflow collectors.

LONGER FILTER LIFE

With less pulsing needed to clean surface-loading nanofiber cartridges, stress on the filters is minimized, resulting in double the filter life of a commodity filter.

A SMALLER DUST COLLECTION SYSTEM FOOTPRINT

The combination of the SFC's patented pulse cleaning system and nanofiber cartridge filters also allow for higher air-to-media ratios, potentially reducing the size of the dust collector and number of cartridges needed for your facility—a significant cost savings overall.

* Minimum Efficiency Reporting Value (MERV) is based on ASHRAE Standard 52.2-1999, and has been deemed the most accurate scale for determining a filter's efficiency and ability to filter submicron dust particles. UAS' MERV 15 efficiency has been tested per this standard by independent lab testing.



Clean air. It's what we do.®

FEATURES AND BENEFITS

Heavy-duty Lifting Lugs

Ensure safe and secure support during installation.

Modular Design

Provides flexibility to increase unit capacity by adding modules at your facility.

Optimized Cartridge Cleaning System

Springless pulse valves and patented nozzle/venturi offer maximized cleaning power.

Horizontal Filters

Quick and easy access when replacing filters.

Heavy-duty Construction

Designed and manufactured to meet Seismic Zone 4 and 100 mph wind load structural rating.



Powder Coated Finish

All components have electrostatically applied paint that prevents fading and chalking.

Quick & Easy Maintenance

With one simple movement of the handle, the SFC's "Quickseal" release door provides extremely fast filter removal and maintenance.



OPTIONS AND ACCESSORIES



Bag-In / Bag-Out Option

provides clean, safe, easy removal of fine, hazardous or difficult-to-handle dusts.



Explosion Relief Vents

minimize damage in the unlikely event of an explosion that may result when collecting explosive dusts.



Digital Pressure Control / Digital Pressure Monitor

allows users to program dust collector for continuous or on-demand pulse cleaning.



Blower Silencer Package

reduces unit noise level to 80 dBA or less under normal operating conditions.

OTHER ADD-ONS

- Abrasive Inlet
- Safety After-Filters
- Fans
- Drum Lid Latch Kit
- Bin Vents
- Short Drums
- Drawer Base
- Service Platforms
- Control Panels
- Pneumatic Valve Assemblies
- Sprinkler Heads

Other options and accessories available. Contact UAS for assistance.

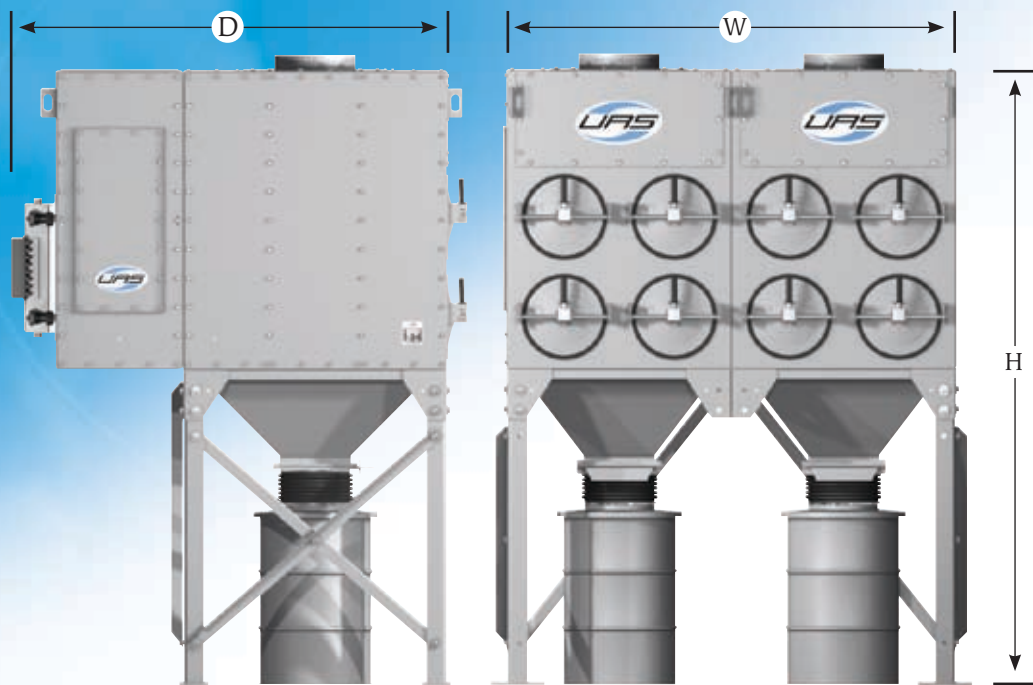

SFC8-2 and Larger with Drum (H55)

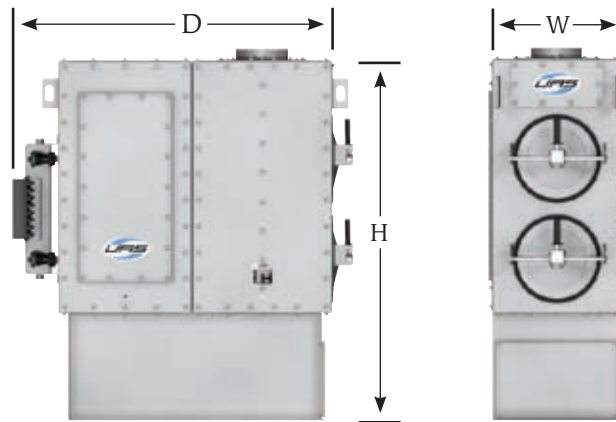

*SFC2-2, 4-2 and 6-3 with Dust Drawer (DD)
(SFC2-2 Shown)*

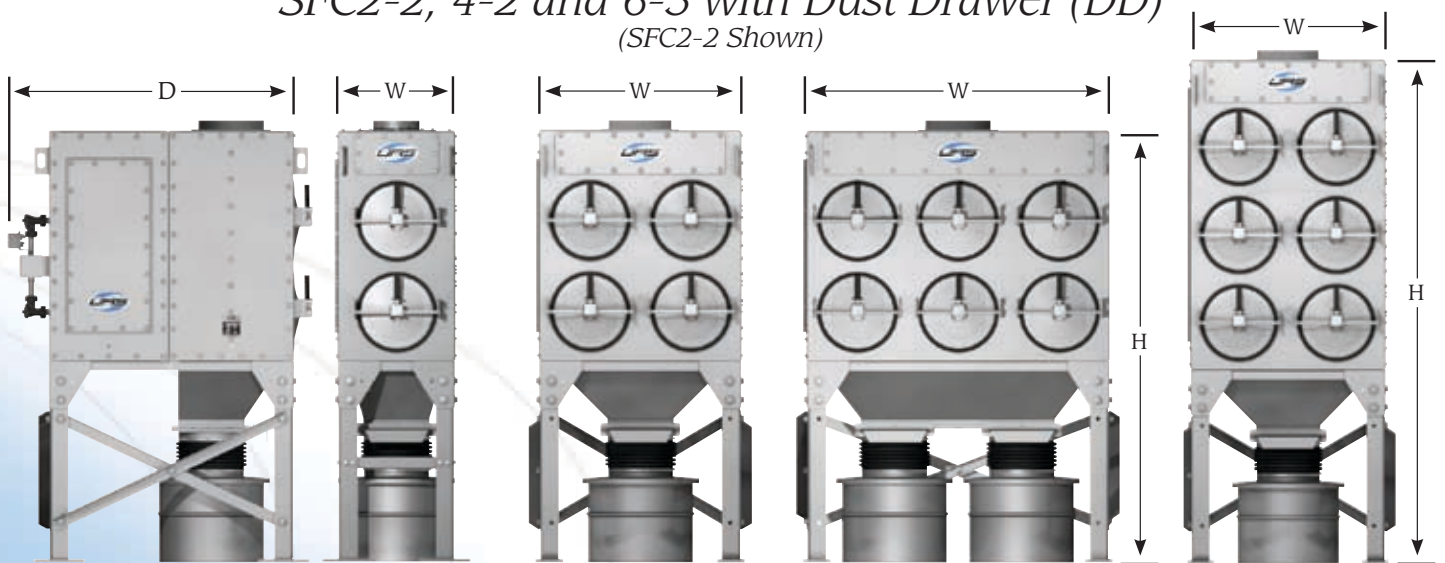

SFC2-2

SFC4-2

SFC6-2

SFC6-3

with Short Drum (SD)



Clean air. It's what we do.®

DIMENSIONS AND SPECIFICATIONS

SFC Models	Filter Quantity	Total Filter Media Area (FT ²)	Valve Quantity	Module Quantity	Unit Weight	Compressed Air Consumption		Height	Width	Depth
					(LBS)	SCF/PULSE	SCFM 6P/Min			
SFC 2 - 2 - SD	2	510	2	1	954	1.7	10.2	7' 8"	2' 1"	5' 1"
SFC 4 - 2 - SD	4	1020	4	1	1317	1.7	10.2	7' 8"	3' 7"	5' 1"
SFC 6 - 2 - SD	6	1530	6	1	1726	1.7	10.2	7' 8"	5' 4"	5' 1"
SFC 2 - 2 - DD	2	510	2	1	890	1.7	10.2	5' 4"	2' 1"	5' 1"
SFC 4 - 2 - DD	4	1020	4	1	1197	1.7	10.2	5' 4"	3' 7"	5' 1"
SFC 6 - 3 - DD	6	1530	6	1	2020	1.7	10.2	6' 11"	3' 7"	5' 1"
SFC 6 - 3 - SD	6	1530	6	1	1726	1.7	10.2	9' 4"	3' 7"	5' 1"
SFC 8 - 2 - H55	8	2040	4	1	1922	1.7	10.2	10' 3"	3' 9"	7' 3"
SFC 16 - 2 - H55	16	4080	8	2	3237	3.4	20.4	10' 3"	7' 6"	7' 3"
SFC 24 - 2 - H55	24	6120	12	3	4552	5.1	30.6	10' 3"	11' 3"	7' 3"
SFC 32 - 2 - H55	32	8160	16	4	5947	6.8	40.8	10' 3"	15' 0"	7' 3"
SFC 12 - 3 - H55	12	3060	6	1	2420	1.7	10.2	11' 11"	3' 9"	7' 3"
SFC 24 - 3 - H55	24	6120	12	2	4016	3.4	20.4	11' 11"	7' 6"	7' 3"
SFC 36 - 3 - H55	36	9180	18	3	5612	5.1	30.6	11' 11"	11' 3"	7' 3"
SFC 48 - 3 - H55	48	12240	24	4	7288	6.8	40.8	11' 11"	15' 0"	7' 3"
SFC 60 - 3 - H55	60	15300	30	5	8884	8.5	51	11' 11"	18' 9"	7' 3"
SFC 72 - 3 - H55	72	18360	36	6	10480	10.2	61.2	11' 11"	22' 6"	7' 3"
SFC 16 - 4 - H55	16	4080	8	1	2873	1.7	10.2	13' 7"	3' 9"	7' 3"
SFC 32 - 4 - H55	32	8160	16	2	4762	3.4	20.4	13' 7"	7' 6"	7' 3"
SFC 48 - 4 - H55	48	12240	24	3	6651	5.1	30.6	13' 7"	11' 3"	7' 3"
SFC 64 - 4 - H55	64	16320	32	4	8620	6.8	40.8	13' 7"	15' 0"	7' 3"
SFC 80 - 4 - H55	80	20400	40	5	10509	8.5	51	13' 7"	18' 9"	7' 3"
SFC 96 - 4 - H55	96	24480	48	6	12398	10.2	61.2	13' 7"	22' 6"	7' 3"
SFC 112 - 4 - H55	112	28560	56	7	14367	11.9	71.4	13' 7"	26' 3"	7' 3"
SFC 128 - 4 - H55	128	32640	64	8	16256	13.6	81.6	13' 7"	30' 0"	7' 3"
SFC 20 - 5 - H55	20	5100	10	1	3400	1.7	10.2	17' 6"	3' 9"	7' 3"
SFC 40 - 5 - H55	40	10200	20	2	5700	3.4	20.4	17' 6"	7' 6"	7' 3"
SFC 60 - 5 - H55	60	15300	30	3	7900	5.1	30.6	17' 6"	11' 3"	7' 3"
SFC 80 - 5 - H55	80	20400	40	4	10250	6.8	40.8	17' 6"	15' 0"	7' 3"
SFC 100 - 5 - H55	100	25500	50	5	12600	8.5	51	17' 6"	18' 9"	7' 3"
SFC 120 - 5 - H55	120	30600	60	6	14950	10.2	61.2	17' 6"	22' 6"	7' 3"

Short Drum (SD) units available in SFC 8 and larger. Subtract 16" from height.

WHY CHOOSE UNITED AIR SPECIALISTS?

A world-renowned reputation. For more than 40 years, we've been the industry leader in air quality technology — a proven track record that speaks for itself.

Commitment to quality products. Measuring our quality against documented expectations, we practice continuous improvement methods to anticipate challenges and implement successful solutions.

Unparalleled customer support. As a customer-driven solutions provider, we earn credibility and establish successful relationships by exceeding expectations for professional service and attitude.

Innovative technical leadership. Always, we keep technology at the forefront — ensuring continuous product advancements through ongoing investments in design and manufacturing.

UAS HEADQUARTERS – USA

4440 Creek Road
Cincinnati, Ohio 45242
Ph: 513-891-0400
1-800-252-4647
E-mail: info@uasinc.com
www.uasinc.com

UAS – GERMANY

Otto-Hahn-Strasse 6
D-65520 Bad Camberg
Ph: +49-6434-94220
E-mail: info@uas-inc.de
www.uas-inc.de

UAS – UNITED KINGDOM

PO Box 17
Folly Lane
Warrington, Cheshire
England WA5 0NP
Ph: +44-1925-654321
E-mail: uas@clarcoruk.com
www.uasuk.com

UAS – ASIA

Flat 1, 15/F, Block 1
Grand Pacific Views, Palatial Coast
Siu Lam, Tuen Mun
New Territories, Hong Kong
Ph: +852-2814-7722
E-mail: dlee@clarcor.com



a CLARCOR company

Clean air. It's what we do.[®]